

ACADEMY NEWS



Department News

“Viva La Italia” - Bormio 2023

The outstanding “We Will Rock You” performance

Latest Sports Results: Football and Netball

Introducing our New SSLT.

Sir Robert Pattinson Academy
Newsletter Issue 126
Spring 2023

Welcome to the latest edition of our termly newsletter.

Dear Parent/Carer

Thank you for taking the time to read our latest end of term newsletter. Our staff and students have been very busy since the turn of the year and this newsletter encapsulates all of those successes. It is always great to see success stories from across the whole Academy, from shows to sixth form trips and I remain very pleased with how the Academy continues to perform. Our subject faculties and departments continue to shine on many fronts as we approach the end of our platinum jubilee year. With this particular event in mind, we have now published our plans for a full three months of activities and celebrations so that all of our students can learn and benefit from the experience. There are also some surprise events coming up too which should enthuse everyone, but I will remain tight-lipped on that score until the beginning of term 5...

We all wish you a restful Easter break and hope that you all have the chance to unwind over the coming fortnight.

Mr D Hardy
Headteacher



Forthcoming Events

Summer Term	SRPA Platinum Jubilee Celebrations
Apr 2023	
Wednesday 26	UKMT Junior Maths Challenge
Jul 2023	
Thursday 06	Year 6 Transition day
Friday 07	Year 6 Transition day
Tuesday 11	Academy Sports Day
Thursday 13	Reserve Academy Sports Day



Term Dates

Mar 2023	
Friday 31	End of Spring term
Apr 2023	
Monday 17	INSET Day
Tuesday 18	Start of Summer term
May 2023	
Friday 26	End of term
June 2023	
Monday 05	First day of term
July 2023	
Friday 21	End of term



Staff Changes

New Teaching Staff

Miss C Baldwin	School Led Tutor
Mrs D Enright	Religious Studies
Miss B Gibbs	Design and Technology
Ms N Kelter	Art and Photography
Mrs N Hutchinson	Second in Dept, Performing Arts
Mr P Fell	Science

New Support Staff

Mrs D Garrett	Human Resources Manager
Miss L Timbrell	Headmaster's PA
Miss A Wilford	Cleaner
Mrs L Hurton	Science Technician

Leavers

Miss F Swindale	Science Technician
Mr M Coakeley	Technology Technician
Miss H Stevenson	Academy Counsellor
Miss L Pattison	Academy Counsellor
Miss L Earnshaw	Art and Photography
Miss R Andersen	Religious Studies
Dr C Whitmore	Science
Miss C Whelan	Mathematics





English Department

It seems hardly any time has passed since the autumn term newsletter – probably because we have been so busy in the department that the time has flown by! In January, 125 Year 11 students visited the Theatre Royal in Nottingham to see *An Inspector Calls* and, by all accounts, had a fantastic time. The staging of the production offered some nice surprises and gave students an invaluable opportunity to see one of their GCSE Literature texts brought to life on the stage. We were extremely proud of our students during the visit and it was to their credit that a member of the public took the time later to email Mr Hardy to praise their ‘impeccable’ manners and behaviour and to comment that our students had contributed to her having a ‘thoroughly enjoyable afternoon’. Overall, this visit was a huge success and we look forward to more visits to see literature in performance as and when the opportunities arise.



By the time this newsletter is printed, 60 of our Year 9 students will have visited the National Justice Museum in Nottingham, linked to their current study of the play *Twelve Angry Men* which forms part of our US Literature unit. The museum houses a Victorian courtroom, Georgian gaol, and cells that date back hundreds of years, and offers students the chance to step back in time and hear real stories from the history of the gaol, as well as the opportunity to participate in a mock trial. Planning is also underway for a Year 8 trip to see Southwell Workhouse as part of their study of Victorian literature in the summer term. As a department, we are really enjoying the chance to show students how their study of English relates to the world around them and seeing how that translates into improved understanding of the texts we read in the classroom.



Our Subject Champions have been busy this term too. Before half term our KS3 Champions produced the promotional material for our short story competition and will be responsible for judging the entries when the competition closes at the end of term. Our KS5 Champions were on hand during Year 9 options evening to talk about GCSE Media Studies from a student perspective, giving invaluable advice to our younger students and ably assisting Mrs Murdoch with her subject presentations. As we finish the term, Mr Chetwynd has set our Year 9 and Year 10 Champions the task of choosing a new set text for Year 9, to fit into our Literature from Other Cultures unit which will be launched in 2023 - 2024.

Lastly, we can't end our contribution to the newsletter without mentioning our fantastic Year 11 and Year 13 students who continue to prepare for their examinations with determination and vigour. Attendance at our after school masterclasses for Year 11 has been steadily increasing over the course of the term and our Year 13 Language students have impressed us with their efforts in revising for the mock examinations. When the next newsletter is released, the examinations for both these year groups will be complete, so we take this opportunity to wish all of them well in A Level Language, GCSE English Language, GCSE English Literature and GCSE Media Studies.

<https://srpa.co.uk/our-curriculum/subject-curriculum/> - select English Curriculum link

www.instagram.com/Srpaenglish



World Book Day 2023

After the success of last year's World Book Day celebrations, Mrs Murdoch, our whole school reading lead, organised another fantastic day this year. Students in Years 7 to 11 were introduced to five extracts from five novels over the course of five lessons and given the opportunity to review each one on a specially made review sheet which students carried with them for the whole day. Many of the review sheets handed in showed an exceptional level of engagement with reading from students across KS3 and KS4 and it was a pleasure to see students reading and responding to texts which they might never have thought to pick up just from the front cover alone. Winning review sheets were chosen from each year group and house and the students who completed them have won a copy of the book which most intrigued them from the five they were introduced to on the day.



A World Book Day inspired book swap is also planned, giving students another opportunity to try something new that they perhaps wouldn't have read otherwise. Mrs Ransome, Librarian, gave out book tokens on the day too for students to redeem against any of this year's nominated books. The Library is always full, every break and lunchtime, but the atmosphere on World Book Day is always extra special and this year was no different. We hope that this year's celebrations have inspired even more of our students to say: *'I am a reader'*.

Young Writers

Anyone who entered the Integer 100 word competition has been contacted regarding permission to publish, and the book will be out shortly. Copies will either be sent directly to the students' homes, or delivered to school and sent home with students. It is fantastic to see so many of our students wanting to write creatively and a real source of pride to have so many published authors in our school!

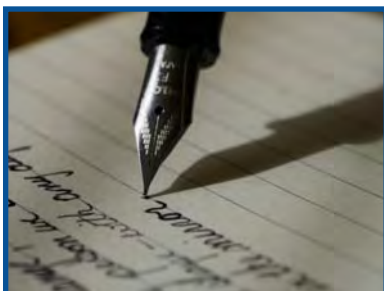



The Art, Photography and Technology department has had a great start to 2023, we have had the wonderful opportunity to display all the different talents we have here within the Academy. We have challenged our students with PD Day activities, multi-media experimentation, Options evening, subject champion meetings and KS4 curriculum catch-up sessions.

Curriculum Delivery

Year 7 Artists have been looking at line art and have been recreating their own masterpieces in a triptych style. They have put together all their knowledge of line and tone to refine the thicknesses of line to create outcomes inspired by Carl Krull. For homework, our artists have been using photography to explore line and have made some exciting outcomes.

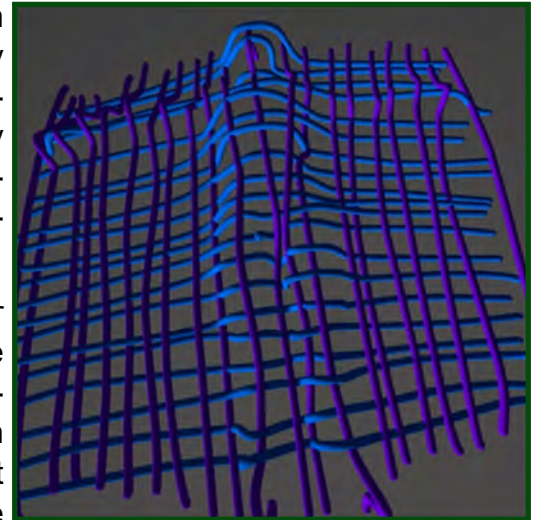

Year 8 Artists have been working on developing their knowledge of tone and design by creating their own gargoyle drawings inspired by the Lincoln Imp. They have been exploring the history of the gargoyle and how it has changed in modern day to become more of an ornament. In the next term, students will create their own 3D gargoyles out of wire and clay.



Year 9 have been exploring their understanding of clay by creating their own 3D outcomes of different food items. They have then began to explore photography by using cameras in a studio setting to experiment with lighting. The students have then moved onto composition to help develop their understanding of layout in preparation for GCSE Art or Photography.

GCSE Art and Photography students have begun their coursework this term. They have been given the topic titles of; facades, man vs nature, food and drink, groups and childhood. They have had to choose one of these topics and begin to develop a portfolio based around that topic. Artists have begun their initial observations in drawing form and photographers in a digital photography form.

Our Year 7 Technologists have been focusing on exploring their understanding of health and safety within the workshop. They have then taken this knowledge and applied it whilst exploring wood types, cutting and adhesion processes to create their own pen pots. Within Food and Nutrition Year 7's are developing their knife skills, learning how to use a peeler and how to correctly dice an onion making crudites for their first practical, spicy tomato soup and apple crumble. This will also start their journey in learning how to use a hob and oven safely. Alongside this they have been learning about the Eatwell Guide and the different nutrients our body needs. As an important factor of the course students have been asked to evaluate each practical for their homework to reflect on their skills and where they can improve.





Art and Technology Department

Year 8's have focused on exploring arts and crafts design movement and how they can come up with won coaster inspired by the movement. Learning the intricacies of CNC (Computer numeric control) they have worked on casting in the workshop, creating their own unique creative designs that are both high quality and eye-catching.



Year 9 have had the homework tasks to create chairs. Some made miniature versions, and some went above and beyond the scale expectations! Lyla D created a chair using steel rebar, pallet wood and other supplies and produced a chair fit for a king. Students have also been working on developing their understanding of isometric drawings by sketching pencil sharpeners and then moving up to bottles.

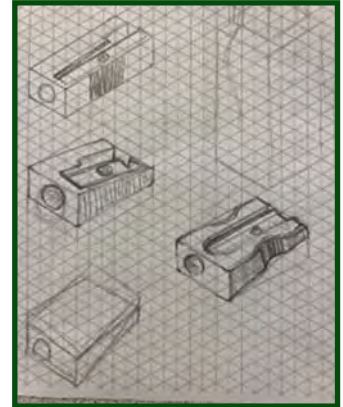

During their lessons, the Year 10 students are expanding their knowledge of metals by exploring the same practical sessions as KS3 but with more of a focus on the theory behind the material and practical skills. All the creators within Design and Technology have worked hard exploring the various tools, machines and processes involved in the practical based lessons.

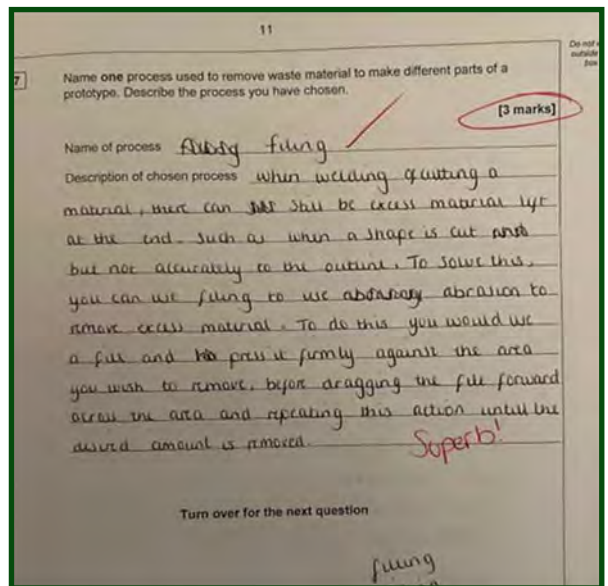

Our Year 11's have been working hard preparing for their upcoming exams. In tech, they have been revising by doing exam style questions and continuing their practical coursework by making their final products. In Art and Photography, students have been working on their exam unit by creating a portfolio of evidence refining experiments to come up with a final piece idea for the exam in April.

Within our development of the schemes of learning we have introduced careers in our starters to ensure students understand where the lesson could take them. We want students to make links to the knowledge or skill developed in the lesson allows them to take many different pathways in their future careers that are not only in our subjects but in many different subjects across the Academy.

Politician	Jeweller	Civil Engineer
A politician is a person active in party politics, or a person holding or seeking an elected office in government. Politicians propose, support, reject, and create laws that govern the land and, by extension, its people.	Jewellers use various tools and techniques to make jewellery from metals, diamonds, gems and other materials. They also cut, clean and polish precious stones, and sometimes do the necessary research and evaluation to value rings, earrings, bracelets, etc.	Civil engineers plan, design and oversee construction and maintenance of building structures and infrastructure, such as roads, railways, airports, bridges, harbours, dams, irrigation projects, power plants, and water and sewerage systems.

What path could I take from this lesson...



Student Experience

We want to thank you for your hard work this term. We have been delighted with your engagement with our Instagram posts, clubs and displays over the last few weeks and we have had the honour of being able to display your work on our Instagram page. We have been able to showcase and share your creations with students, staff and parents/carer and are overjoyed with the outcomes. We have enjoyed exploring the ways we have used Instagram to engage students with fun activities. We have shared live stories and QAs with you all. Mr Webster was overjoyed to learn he won the apple vote.



We want to congratulate our GCSE Food students in the completion of their food technology practical exam. During this, they had a short time

period to create two dishes that were taste tested, reviewed and scored by staff. Overall, we are amazed with the complexity and confidence of the dishes created and students should be proud of the outcomes, they tasted delicious.

Before we broke up last term, our food technologists were able to provide the food for our very first gala night for our Academy show. Our students provided canapes and they went down a treat! They made each meal in the food rooms and made a menu to ensure all guests knew what ingredients were used.



Our KS5 subject champions worked closely with Mr Webster to create a gate in a day! They worked tirelessly to create the golden gates for the Academy show. On opening night they were shining bright and showcased just how talented our students are.





Art and Technology Department

Over the past few weeks students have been collecting their aprons to use in their practical lessons. Anyone who ordered one and has not collected one, please go to the Art and Technology office any break time to collect your apron.

These aprons can be used across all of your practical subjects in our department. If you receive Star of the Term and you have an apron, you will receive a badge that can be attached to your apron! If you have 100% attendance at a club, at the end of the year you will also receive a club badge that can sit proudly next to the school logo. The more badges the better!



<https://srpa.co.uk/our-curriculum/subject-curriculum/> - select At and Technology link

www.Instagram.com/Srpaartandtechnology



Hosted by the School of Computer Science at Lincoln University - 9 March 2023

Year 12 A-Level Computer Science students attended a day of inspiring sessions put on by the School of Computer Science at Lincoln University to advertise their courses for their next steps in education. The day included discussing the future of technology in education, a robotics building task using

some toothbrush heads, a session on video game development lead by a former video game developer and a session on computer science where they used Google APIs and a mobile phone to take photos of each other and put through the API to detect firstly emotions that were present on their faces and then object detection exploring how machine learning works on a world wide scale.

The students had a fun and engagement (though sometimes challenging) day but rose to the challenge and completed all activities fully.



Student Comments

"Robotics was pretty fun, I liked building the little robot and messing around with the code for the videogame and changing values was also really fun."

"The trip was very fun. I'd say the most enjoyable part was the robotics, it was really engaging and gave me a good understanding of what characteristics make up a robot. The other parts of the day were also enjoyable and seeing the computing environment at the university was extremely interesting."

"I enjoyed the day out to the university, this was because I was able to view the course details and facilities, this was helpful in case I would like to pursue a undergraduate degree in Computer Science."



Humanities Department - International Women's Day



On Wednesday 8 March 2023, we celebrated International Women's Day. Students attended assemblies on this year's theme, IWD: Embrace Equity. The Humanities department led a competition for students to identify influential figures who have either advocated for equality, or been an inspirational woman within her field. There were 16 characters from the Humanities department and our Year 12 students who walked the corridors for students to see their costume and clues. Students got involved by guessing as many as possible. Entrants for the competition were able to identify many of these famous faces, but it was Morgan in Year 11 who managed to name all 16 correctly! Well done, Morgan.



Eleanor, Martha and Evie in Year 12 added to the International Women's Day celebrations with their request to give IWD notes to teachers to thank them for their efforts. This wonderful request from our students saw students thanking their teachers for being an inspiration, a game changer, for giving time to their students, to name but a few. There was a lovely atmosphere around the Academy as student delighted in handing out their notes. Thank you to Eleanor, Martha and Evie for your suggestion.





Humanities Department - Debate Team



This term marked the start of the key stage 3 debate club. Year 9 worked on their debating skills and the art of critical thinking by examining counter arguments and how to 'pick apart points'. Students practiced thinking on their feet and developed their research skills.

The first Year 9 debate took place this term with Miss Bennett acting as a judge. The question was "This house believes that there should be a mandatory quota to ensure there is 50% female representation in parliament".



Students discussed the following points,

- Parliamentary constituencies and how quotas would work with the current electoral system.
- If quotas would make women feel they deserved their position.
- Other ways to encourage more women to stand for election.
- The benefits of having women in charge.
- How we could make politics more accessible for women.

Students were fantastic and demonstrated passion and enthusiasm during this debate. They are now preparing for a debate on "fast fashion" after Easter and are looking for new topics all the time to help them prepare for a very special inter-schools' debate during the summer term.





Performing Arts Department - We Will Rock You

With a cast of almost 80 student, and a crew of over 20, this year's production of 'We Will Rock You' demonstrated just how incredible an inclusive arts programme can be.

We are so proud of every student involved in this show and grateful to the amount of support we received from the Academy community over the five performances.

Our young people demonstrated an incredible level of professionalism and talent and we can't wait to see what they do next!



WE WILL
ROCK
YOU





Performing Arts Department - We Will Rock You





Performing Arts Department - Splendid Workshop

This term the Performing Arts department was visited by Splendid Productions to lead a workshop with Year 10, 12 and 13 around devising techniques and practitioners. It was a fantastic opportunity for the students to work with such a renowned theatre company, who have been nominated for a prestigious Olivier Award this year for their work on 'Midsummer Mechanicals' at Sam Wanamaker Playhouse. The students left the workshop inspired to start their devised examination performances.



**SPLENDID
PRODUCTIONS**





Sixth Form - SSLT

Following a lengthy application process involving interviews with Mr Griffiths and Miss Walker, and then second interviews with Mr Hardy and Mrs Spoons, we appointed our new Senior Student Leadership Team (SSLT). Students were asked to present their ideas about changes that they would make within the sixth form or the Academy before having a 5 minute interview focusing on previous experience that they could bring to the role and skills that they would like to develop.

Introducing 2023-2024 Senior Student Leadership Team:



Hi, I'm Carlos and I am Head Boy. I'm studying Physics, Mathematics, and Computer Science and hope to work in the aerospace industry after university. In my free time, I love cycling, running, and photography. As part of the SSLT team, I'm excited to collaborate with my fellow students to make our school a more welcoming and comfortable place for everyone. I'm looking forward to working with my friends and peers to make positive changes that will benefit our school community.

Hi, my name is Katie, and I am the Head Girl at RP6th. I am currently studying History, Biology, and Physics at A-Levels. My aim is to have a positive impact at this Academy and not only listen to the loudest voices but also the quieter ones in the room. I am also excited to be working with other members of SSLT, teachers, and students I wouldn't have otherwise had the chance to get to know and hear new ideas that will aid in the improvement of the school and the well-being of students.



Hi, I'm Oliver, the new Deputy Head Boy. I am currently studying Biology, Geography and History and hope to go to university to study archaeology. Outside of school, I volunteer as a Young Leader, play the violin and I enjoy listening to music; my favourite artists are Blur and Foals. I am looking forward to being part of the SSLT and working with members of staff. I would like to make a difference in the school, particularly in the Music Department by restarting the orchestra.



Sixth Form - SSLT

Hi, my name is Hannah, and I am Deputy Head Girl. I am studying Mathematics, Further Mathematics, Psychology and Sociology and I plan on studying Mathematics with statistical sciences at university. In my role as Deputy Head Girl, I am looking forward to working with my peers on the SSLT, alongside the students and staff of the Academy. I hope to offer insight into ways of improving Academy life, to leave a positive mark on SRPA.



Hello, my name is Shannon, and I am currently studying History, Geography and English Literature. I hope after my A-Levels to go to university to become a History and Geography teacher. In my free time, I volunteer as a young leader at a local Brownies unit, and I am also a Ranger in Girlguiding. I love to travel and have new experiences and learn about other cultures. I have a passion for History and Geography outside of school and like to visit historical and geographical places like visiting volcanos in Pompeii. I am looking forward to being chair in SSLT and hope to contribute to have a positive impact on the Academy.

Hello, my name is Livia, and I am the Extra-curricular/Enrichment Lead and Social Media Lead. I have played rugby since I was 11 and I play for Nottinghamshire, Lincolnshire and Derbyshire. I am a professional coach at Rugbytots where I coach children aged 2 – 7 and I volunteer at Lincoln rugby to coach a variety of mini teams. When in school, I use my experience of coaching to support Year 7 and 8 PE lessons. I also have a love of science and volunteer with STEM club as well as supporting in younger years science lessons. Furthermore, I am interested in the social media and enjoy observing what other people post and how the algorithm works. After sixth form, I plan to study Child Nursing at a Russell Group university. I am excited to be part of SSLT at RP6th and to make a difference within the Academy.



Hi, my name is Calum, and I am the Fundraising Lead for the SSLT at RP6th. Currently at Sixth form I am studying Sociology, PE and Geography. After my A-Levels, I am hoping to either go into the RAF as a fighter pilot or go to university and study Criminology. I am still a bit unsure as to which one though. Outside of school, I play Rugby for Newark RUFC where my position is Second Row. Last year I had my greatest achievement as we won the NLD cup. I am excited to be a part of SSLT in my new role and I am looking forward to raising money, not only for school projects and improvements, but also for local charities to help others in the community.

My name is Macy, the Environment Lead, and I am currently studying Art, Sociology and English Literature, in the hope of going into a career within art. Outside of the Academy, I enjoy reading, going shopping, and studying with my friends. Through my role, I aim to make the Academy a more environmentally friendly place and more ecologically considerate of its waste and energy usage.



My name is Grace, and I am currently studying Psychology, Photography and Health and Social care for my A-Levels. I am excited to join the SSLT as Joint Peer Mentor Lead because I am looking forward to helping students and supporting them over their academic journey. I am passionate about students' wellbeing because I believe that all students should have an enjoyable education.



Sixth Form - SSLT

Hi, my name is Eleanor, and I am currently studying History, English Literature and French. In my free time, I enjoy spending time with my friends, listening to music and reading. I am excited to be a part of the new SSLT, I believe it will be a great opportunity for new experiences and to positively impact our school. In my role as Joint Peer Mentor Lead, I am looking forward to working with staff and students to ensure that the peer mentoring system in our school is as beneficial as possible for every student involved.



Hi, my name is Milena, and I am currently taking Biology, Chemistry, and Mathematics. When I am not at school, I enjoy watching movies, listening to music, reading, and spending time with my family and friends. I am an Aspirations Lead and I am looking forward to helping the school improve even further and collaborating with other members of the SSLT, teachers and students to make this happen. By being part of the SSLT, I hope to inspire others to be the best students that they can be.

Hi, I'm Ruby, the new Respect Lead at SRPA. I'm currently in my first year of sixth form, studying for A-Levels in English Language, History, and Sociology. I'm excited to take on my role as part of the SSLT as I've always been passionate about making a difference. Using the skills I have gained through previous leadership roles and experiences, I hope that I will be able to contribute to the creation of a positive and inclusive environment for all students at SRPA. When I'm not studying or volunteering, you can find me watching movies, exploring nature, or spending time with my family and friends. After leaving RP6th, I intend to take a gap year to travel and gain work experience before going to university to study social science.



Hi, I'm Izzi and I'll be the new Personal Development and British Values Lead. I'm excited to be a part of the SSLT. I look forward to new experiences and developing skills that will stand me in good stead for the future. I hope to have a positive impact around the Academy so that my legacy will continue after I leave. I am currently studying Sociology, Psychology, and History. After my A-levels, I hope to work in the field of law. I am undecided as to whether I will go straight to university (my preferences are currently Cambridge and York) or complete an apprenticeship degree. When I'm not at school, I enjoy listening to music, attending my local theatre group, and volunteering which allows me to give back to my local community.

Hi, my name is Martha, and I am currently studying Biology, Psychology and Mathematics. In my free time, I enjoy going to the gym and spending time with my friends and family. I'm excited to be a part of the SSLT as Wellbeing and Reflection Lead, and to see what positive impacts we have on the school and the legacy we leave behind. By working closely with teachers and students, I hope to get the most out of my role by ensuring students feel supported and happy in school.



We have also appointed five associate Student Senior Leadership Team:

- Coby McGhie – to support with Wellbeing
- Neve Jenkison, Shannon McMahon and Chloe Hird – to support with Peer Mentoring
- Bradley Kowalski-Fletcher – to support with Personal Development



Sixth Form—Oxbridge Conference



On Friday 24 March 2023, Mrs Corah took ten Year 12 students to The Priory Academy LSST for the Annual Lincolnshire Oxbridge Conference. Throughout the day, students attended sessions about Oxford and Cambridge Universities.



They found out about the application process including how to write an excellent personal statement, how to pass the interview and how to best prepare for entry examinations. They were able to speak to current Oxbridge University students about life at Oxbridge, how to apply for student accommodation and student finance and were given top tips from current students. A brilliant day had by all!





Sixth Form - National Citizenship Service Changers



As part of the National Citizen Service Changers Toy Box project, the Year 12 NCS group collected toys to distribute to children and bring new life to old toys.

Recycling these toys is not only good for the children who receive them, but also environmentally friendly, as otherwise these toys would most likely find themselves in landfill.

Their inspiration for this project was taken from the fact that we are in a cost-of-living crisis and finances are tight for families with energy bills spiralling. They thought that this project could potentially support families in our local community.

Students and/or parents were invited to bring in old toys they no longer used or needed to the Academy. All the pre-loved toys will be donated to Barnardo's charity shops the week beginning 18 April 2023.



Sixth Form - Personal Development Day

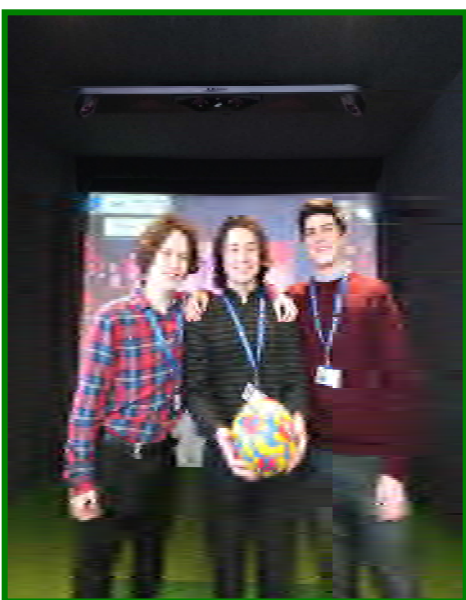

On Tuesday 21 March 2023 our Year 12 and 13 students were involved in a number of activities to support their own personal development and at the same time to support students understand the importance of balancing academic study and looking after their wellbeing with 'stress buster' enrichment activities.

Students were involved in RP6th Independent Living Skills activities such as basic car maintenance and the development of domestic skills. This saw students ironing, sewing on buttons and duvet cover challenges too! In addition, students were developing their culinary skills in our kitchens and also learning about budgeting and managing their own personal

finances.



Our Year 12 students also had a visit off site to Virtually Golf in Lincoln town centre. There were team building activities including carnival games and some golf challenges too, along with refreshments thrown in!

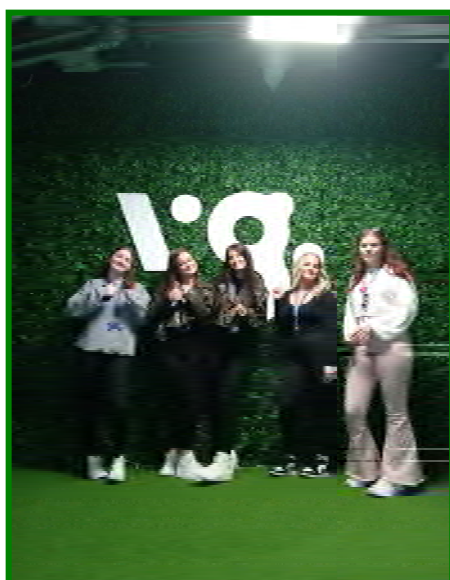



Pathfinders Trip



On Friday 17 March 2023, a group of Year 9 students travelled to Oxford for a trip called 'the Pathfinders'. This is a programme developed at Lincoln College, Oxford, in partnership with the University of Lincoln, offering a continuous contact programme for Year 9 students. The programme introduces students to university life, decision making and academic subjects at both universities with the aim of demystifying these institutions, higher education and providing memorable and fun experiences for them as they go through Year 9 and KS4. Students engaged in various activities throughout the day, including:

mystifying these institutions, higher education and providing memorable and fun experiences for them as they go through Year 9 and KS4. Students engaged in various activities throughout the day, including:

- A virtual walk-through historical archives of the prestigious university
- History and palaeography workshop with university professors
- Astrophysics session explaining some of the wonders of our Universe.

The students had a very enjoyable day and are excited for the next event, which is due to be held at the University of Lincoln to explore further opportunities and insights to higher education.

Itinerary for the day:

10.00-12.00pm - Workshop with Lincoln International Business School hosted by Dr Laura McQuade and Mr Thomas Kitchen

12:00pm – Lunch in the College Dining hall

13:00pm – Walk through Oxford to Lincoln College Archives

13:20pm – History and Paleography workshop with Lincoln College Archivist Lindsay McCormick and Dilts Fellow Dr Laure Miolo

14:20pm – Walk back to College

14:40pm – Astrophysics session with Oxford Physics Department's Dr Oscar Barragan

15:15pm – Farewell and next steps

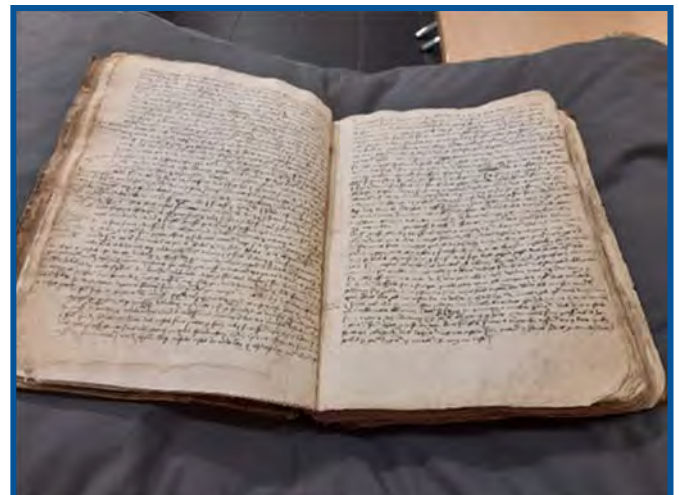



Bormio Ski Trip 2023

During February half term, 72 students and 9 staff embarked on the adventure of a lifetime. We departed SRPA at 4:30pm on the Thursday and started the epic journey to Bormio in Italy. It was a long journey, made enjoyable by the on-coach entertainment, a range of DVD's and singing on the party bus (not forgetting the chips and milkshakes in the service station in Switzerland). We finally arrived at our hotel Villa Rina in Bormio at 8:30pm on the Friday. We took our bags into the hotel and went straight out to dinner, where we enjoyed our first experience of authentic Italian pasta. What we didn't know was that it was the first of many to come. We then settled into our rooms and went straight to sleep.



The next day was Saturday. We were awoken particularly early by the brilliant wake up call, followed by breakfast. Then it was a nice walk to the ski hire shop, then up the gondola to the 2,000m station. We met our instructors, and the lessons began. The intermediate group were quick to disappear up the ski lifts and they spent the day skiing down a wide range of slopes. In the afternoon, they skied down to the town and down part of the 'World Cup' run and a section called the 'Wall'. This lived up to its name and was a sheer vertical section of the slope. This was challenging to negotiate, far easier for the elite racers who literally flew over this section! The beginners had a brilliant day learning the basics on the nursery slopes around the 2,000m level, getting to grips with the fundamentals of ski control.





Bormio Ski Trip 2023

It was quite warm and despite being surrounded by snow, the Alps did not have as much snow as previous years. It was noticeably melting by the end of the week, with high temperatures and no snowfall during the week.

Despite this we had a brilliant week of learning to ski and snowboard. Everyone got to go up to the top of the mountain at 3,000m above sea level. As the week progressed, so did our students, improving their ski and snowboarding techniques and progressing from the nursery slopes. All students had a brilliant week and improved throughout the trip. At times, the skiing was physically demanding and hard, but it was a great opportunity for the students to show how resilient they were, and the discomfort was worth it for the thrill of flying down the mountain enjoying the spectacular scenery.

The evenings were a chance to unwind after a day of full on skiing and boarding, but at the same time, were packed full of activities. One night, we had a really enjoyable and competitive quiz, hosted by Mr Whitley and Miss Evans, with a not to be forgotten music round, sung (in the loosest sense of the word) by Mr Whitley. We went to a local venue to have a disco and Karaoke night, the karaoke was so popular we didn't get much disco dancing done. It was brilliant to see the students from Years 8 to 13 getting involved, and supported by the teachers. It was a very enjoyable night. We spent an evening visiting the shops and ice cream shops of Bormio. We went ice skating for an evening and the fun evening was concluded with a recreation of Torvill and Dean's Winning 1984 Olympic Bolero. The last night, we enjoyed a presentation of certificates by the ski school, a video of our weeks skiing highlights and pizza. The pizza kept coming and it was a brilliant end to the week, before we embarked on the mammoth journey back to Lincoln (which strangely seemed shorter on the way home).

The trip was brilliant and made even more enjoyable by the students on it who were a credit to themselves and the Academy.

Thank you to all the staff who gave up their half term to take the students to Italy.

We are looking forward to the 2024 ski trip which Mr White is organising.





Attitude to Learning (A2L)

At Sir Robert Pattinson Academy, we run a highly successful Attitudes to Learning Programme designed to support our pupils to achieve their very best. The programme has the following aims:

- *To drive engagement, aspiration, goals and resilience*
- *To encourage pupils to be more engaged with their learning, have a thirst and curiosity to know more, do more and be more.*



The A2L programme centres on developing and instilling 5 key attributes within our pupils. These are; *willingness to learn, resilience, motivation/determination, teamwork and the ability to reflect*. We believe these attributes are crucial in ensuring good behaviour and maximising progress for our pupils. Each term, subject teachers will complete an *A2L Assessment*. They will make a judgement based on pupil A2L and grade then as one of 4 types of learner - *Expert, Highly Effective, Effective or Developing*.

Expert learners are taking responsibility for their education and beyond. Becoming an expert learner is an outstanding achievement.

Highly Effective learners have a few target areas to work upon to become an expert learner but are showing many of the qualities needed to succeed.

Effective learners have a mixture of positive attitudes and a number to work upon.

Developing learners need to address a number of areas but have the potential to improve with all of the support available.

Expert learner	800 house points
Highly Effective learner	600 house points
Effective learner	400 house points
Developing learner	200 house points

From all the grades that a pupil receives, an overall A2L grade is calculated. This overall grade will earn pupils the following house points:

Following an A2L assessment, pupils will complete an A2L review as part of the R2L tutor programme. This can be seen in the pupil planner. Pupils will note their grades and set themselves targets to improve.

Pupils who have been graded overall as a Developing Learner or those that we feel are at risk of becoming a Developing Learner, will begin the *A2L Booster* intervention programme with the aim of improving their attitude towards learning. Pupils on this programme will receive a letter home informing parents and will begin a Booster report, which is led by the R2L tutor and monitored by the House team. Pupils with the greatest need will also receive mentoring from a member of staff who will work with them to improve their A2L. Pupils who are successful and improve their A2L grade will complete the programme. Those who are not will receive further intervention and support.

We are incredibly proud of our Expert Learners and see this as the benchmark that all pupils should aspire to reach. Expert Learners will be recognised and rewarded at different points throughout the year and those who show they are consistently an Expert Learner will receive an Expert Learner badge from the Head Teacher.

We are extremely proud of how well our pupils have engaged with the Academy's A2L programme so far this year. Parental support is a key factor in the success of the A2L programme and is always greatly appreciated. If you would like more information, you can visit the Academy website or contact your child's R2L tutor in the first instance.



As Term 4 finishes, so do the football and netball seasons. With 56 fixtures being played, all the results and final league positions for each team can be seen below. Congratulations to all that have been involved. We now move onto cricket, tennis and rounders fixtures in the summer term.

Football



Year 7 Football fixtures



Wednesday 5 th October Goals: Harrison J x4, Oliver C x4, Tommy S x3, Harry S, Gabriel C, Harrison C	v. Priory Witham (home)	League	Won 15-0
M.O.M. Harrison J			
Monday 10 th October Goals: Harry S	v. The King's School (away)	National Cup 2 nd round	Lost 1-7
M.O.M. Harry S			
Friday 13 th January Goals: Harrison J	v. The Kings School (home)	County Cup 2 nd round	Lost 2-4
M.O.M. Riley G			
Wednesday 22 nd February Goals: Harrison J x3, Tommy S, Ryan M x2, Oliver C, Harrison C, Harry S	v. North Kesteven (home)	League	Won 9-0
M.O.M. Tommy S			
Tuesday 28 th February Goals: Oliver C x4, Ryan M, Harrison J	v. Priory City (away)	League	Won 6-3
M.O.M. Oliver C			
Wednesday 8 th March Goals:	v. Branston CA (away)	League	Lost 4-0
M.O.M. Finley M			

Competition: Year 7

League 1									
#	Team	P	W	D	L	F	A	GD	PTS
1	BRANSTON COMMUNITY ACADEMY 1	4	4	0	0	19	1	18	12
2	Sr Robert Pattinson Academy	4	3	0	1	20	7	13	9
3	Priory City of Lincoln Academy	4	2	0	2	18	15	3	6
4	North Kesteven Academy	3	0	0	3	3	14	-11	0
5	The Priory Witham Academy	3	0	0	3	0	25	-25	0





Football



Year 8 Football fixtures



Tuesday 20 th September	v. Priory City (home)	League	Won 6-3
Goals: Freddie Z x2, Kal C x2, Harry S x 2			
Thursday 6 th October	v. William Farr (away)	National Cup 2 nd round	Won 4-1
Goals: Brian B x3, Oscar L			
Thursday 13 th October	v. Minster (home)	League	Won 11-0
Goals: Harry S x3, Jack M x2, Josh V x2, Oliver S, Kal C, Brian B, Cohen C			
Thursday 3 rd November	v. Humberston A. (away)	National Cup 3 rd round	Lost 0-2
Goals:			
Friday 13 th January	v. Priory Pembroke (home)	County Cup	Lost 0-1
Goals:			
Thursday 9 th February	v. Branston CA (home)	League	Lost 4-6
Goals: Brian B x3, Harry S			
Wednesday 22 nd February	v. North Kesteven (home)	League	Won 6-0
Goals: Cohen C, Harry S, Brian B, Olly M x2, O.G.			

Competition: Year 8

League 1									
#	Team	P	W	D	L	F	A	GD	PTS
1	BRANSTON COMMUNITY ACADEMY 1	4	4	0	0	24	5	19	12
2	Sr Robert Pattinson Academy	4	5	0	1	23	9	14	9
3	Priory City of Lincoln Academy	3	1	0	2	9	16	-7	3
4	North Kesteven Academy	1	0	0	3	2	14	-12	0
5	Lincoln Minster Senior	2	0	0	2	0	14	-14	0





Football

Year

9

Year 9 Football fixtures



Tuesday 20 th September	v. Priory City (home)	League	Won 6-1
Goals: Cameron M x 3, Fraser I x2, Lennon S M.O.M. Cameron M			
Wednesday 5 th October	v. William Farr (away)	National Cup 2 nd round	Won 4-2
Goals: Riley S x2, Bailey B, Alex C M.O.M. Fraser I			
Tuesday 11 th October	v. Minster (home)	League	Won 8-0
Goals: Cameron M x2, Bailey B x2, Fraser I, Riley S, Dylan T, Lennon S M.O.M. Dylan T			
Thursday 10 th November	v. UA Holbeach (away)	National Cup 3 rd round	Won 3-2
Goals: Cameron M x 2, Bailey B M.O.M. Cameron M			
Tuesday 15 th November	v. Bourne Grammar (away)	County Cup 1 st round	Lost 5-8
Goals: Frazer I x 2, Cameron M, Toby M, Bailey B M.O.M. Bailey B			
Thursday 1 st December	v. Boston Grammar	National Cup 4 th round	Lost 1-2
Goals: Cameron M M.O.M. Keaton S			
Wednesday 22 nd February	v. Priory Witham (away)	League	Won 12-0
Goals: Finn H, Toby M, Cameron M x3, Fraser I x3, Lennon S x2, Bailey B, O.G. M.O.M. Alfie E			
Wednesday 8 th March	v. Branston CA (away)	League	Lost 2-7
Goals: Theo R, Bailey B M.O.M. Keaton S			

Competition: Year 9

League 1									
#	Team	P	W	D	L	F	A	GD	PTS
1	BRANSTON COMMUNITY ACADEMY 1	5	5	0	0	28	3	+25	15
2	Sir Robert Paterson Academy	4	3	0	1	22	8	+14	9
3	Priory City of Lincoln Academy	4	2	0	2	12	16	-4	6
4	North Kesteven Academy	1	0	0	1	0	3	-3	0
5	The Priory Witham Academy	3	0	0	3	1	14	-13	0
6	Lincoln Minster Senior	3	0	0	3	1	20	-19	0





Football



Year 10 Football fixtures



Tuesday 27 th September Goals: Josh M, Morgan B x 2, Charlie D	v. Minster (home) M.O.M. Morgan B	League	Won 4-0
Monday 3 rd October Goals:	v. The King's School (home) M.O.M. Max S	National Cup 2 nd round	Lost 0-7
Thursday 6 th October Goals: Alden M, Joe C, Morgan B	v. Branston CA 'B' (home) M.O.M. Charlie D	League	Won 3-0
Wednesday 11 th January Goals:	v. Bourne Grammar (home) M.O.M. Daniel S	County Cup	Lost 6-0
Thursday 9 th February Goals: Morgan B	v. Branston CA (home) M.O.M. Morgan B	League	Lost 4-1
Tuesday 28 th February Goals: Regan H, Morgan B	v. Priory City (away) M.O.M. Ethan J	League	Won 2-0

Competition: Year 10

League 1										
#	Team	P	W	D	L	F	A	GD	PTS	
1	BRANSTON COMMUNITY ACADEMY 1A	5	5	0	0	28	3	25	15	
2	St Robert Popsimon Academy	4	3	0	1	9	4	5	9	
3	BRANSTON COMMUNITY ACADEMY 1 B	5	2	0	3	4	12	-8	6	
4	Priory City of Lincoln Academy	3	1	0	2	2	5	-3	3	
5	North Kesteven Academy	2	0	0	2	0	9	-9	0	
6	Lincoln Minster Senior	5	0	0	5	0	15	-15	0	





Football



Year 11 Football fixtures



Tuesday 27 th September Goals: O.G.	v. Branston CA (away)	League	Lost 1-2
Friday 30 th September Goals: Jake M	v. Carre's Grammar (home)	National Cup 1 st round	Lost 1-2 (AET)
Tuesday 11 th October Goals: Wing L	v. North Kesteven (home)	League	Lost 1-4
Monday 9 th January Goals: Corey F	v. De Aston (home)	County Cup	Lost 1-2
Wednesday 22 nd February Goals: Jay R x2	v. Priory Witham (away)	League	Won 2-1
Tuesday 28 th February Goals: Jayden M.P x2	v. Priory City (away)	League	Lost 2-3

Competition: Year 11

League 1									
#	Team	P	W	D	L	F	A	GD	PTS
1	BRANSTON COMMUNITY ACADEMY 1	4	4	0	0	16	8	10	12
2	Priory City of Lincoln Academy	5	2	0	1	19	9	10	6
3	North Kesteven Academy	2	1	0	1	4	4	0	3
4	St Robert Paternoster Academy	4	1	0	3	6	10	-4	3
5	The Priory Witham Academy	3	0	0	3	2	18	-16	0





Netball

Year 7 Netball fixtures



Tuesday 8 th November <i>P.O.M. Amelia M</i>	v. Priory LSST (away) <i>P.P.O.M. Bella T</i>	League	Won 14-3
Monday 20 th March <i>P.O.M. Neve M</i>	v. Branston CA (away)	League	Lost 2-17
Thursday 23 rd March <i>P.O.M. Amelia M</i>	v. Minster (home)	League	Won 17-6

#	Team	P	W	D	L	F	A	GD	PTS
1	BRANSTON COMMUNITY ACADEMY 1	4	4	0	0	61	3	58	12
2	Sir Robert Pattinson Academy	3	2	0	1	32	25	7	6
3	The Priory Academy LSST	4	1	0	3	23	33	-10	3
4	Lincoln Minster Senior	3	1	0	2	12	37	-25	3
5	Priory City of Lincoln Academy	2	0	0	2	0	30	-30	0



Year
7



Netball

Year 8 Netball fixtures



Tuesday 11 th October <i>P.O.M. Neve L</i>	v. Priory LSST (home) <i>P.P.O.M. Rosie C</i>	League	Lost 0-19
Wednesday 19 th October <i>P.O.M. Neve G</i>	v. Branston CA (home) <i>P.P.O.M. Jess Y</i>	League	Lost 0-15
Tuesday 28 th February <i>P.O.M. Rosie C, Eadie W</i>	v. Priory City	League	Won 7-6
Thursday 23 rd March <i>P.O.M. Rosie C, Isabelle S</i>	v. Minster (home)	League	Lost 9-3

#	Team	P	W	D	L	F	A	GD	PTS
1	BRANSTON COMMUNITY ACADEMY 1	4	4	0	0	62	16	46	12
2	The Priory Academy LSST	4	2	1	1	45	21	22	7
3	Lincoln Minster Senior	3	1	1	1	19	24	-5	4
4	Sir Robert Pattinson Academy	4	1	0	3	13	48	-35	3
5	Priory City of Lincoln Academy	2	0	0	2	7	20	-13	0
6	North Kesteven Academy	1	0	0	1	0	15	-15	0



Year 9 Netball fixtures



Tuesday 8 th November <i>P.O.M. Erin</i>	v. Priory LSST (away) <i>P.P.O.M. Anna B</i>	League	Lost 28-3
Tuesday 28 th February <i>P.O.M. Isobel G, Carys L, Neve G</i>	v. Priory City (away)	League	Lost 17-4
Monday 20 th March <i>P.O.M. Carly L</i>	v. Branston CA (away)	League	Lost 15-2
Tuesday 21 st March <i>P.O.M. Anna B</i>	v. Minster (home)	League	Lost 15-0

#	Team	P	W	D	L	F	A	GD	PTS
1	The Priory Academy LSST	5	4	0	1	75	39	36	12
2	Lincoln Minster Senior	3	3	0	0	58	19	39	9
3	BRANSTON COMMUNITY ACADEMY 1	5	3	0	2	65	41	24	9
4	Priory City of Lincoln Academy	3	1	0	2	24	35	-11	3
5	The Priory Witham Academy	2	0	0	2	0	30	-30	0
6	Sir Robert Pattinson Academy	4	0	0	4	8	66	-58	0



Netball



Year 10 Netball fixtures



Tuesday 11th October v. Priory LSST (home) League Lost 3-37
P.O.M. Isabella K P.P.O.M. Carly R

Wednesday 19th October v. Branston CA (home) League Lost 0-15
P.O.M. Isabella D P.P.O.M. Morgan SG

Tuesday 21st March v. Minster (home) League Won 24-5
P.O.M. Morgan S-G P.P.O.M. Phoebe H

#	Team	P	W	D	L	F	A	GO	PTS
1	BRANSTON COMMUNITY ACADEMY 1	5	5	0	0	84	7	77	15
2	The Priory Academy LSST	3	2	0	1	47	29	18	6
3	Sir Robert Pattinson Academy	3	1	0	2	28	39	-11	3
4	North Kesteven Academy	1	0	0	1	0	15	-15	0
5	Priory City of Lincoln Academy	1	0	0	1	0	15	-15	0
6	Lincoln Minster Senior	3	0	0	3	12	66	-54	0





Football



Year 7/8 Girls' 5-a-side football fixtures



Tuesday 22 nd November Goals: Ava D x 2, Ava-Rose M x 2	v. Priory LSST (H) P.O.M. Lucy R	League	Won 4-2
Tuesday 29 th November Goals: Lucy R	v. LCHS (H) P.O.M. Amelia D	League	Lost 1-2
Thursday 5 th January Goals: Ava-Rose M x 2, Lola A	v. Branston (H) P.O.M. Lucy R	League	Won 3-2

#	Team	P	W	D	L	F	A	GO	PTS
1	Sir Robert Pattinson Academy	3	2	0	1	8	6	2	6
2	BRANSTON COMMUNITY ACADEMY 1	3	2	0	1	7	5	2	6
3	Lincoln Christs Hospital School	3	2	0	1	4	3	1	6
4	The Priory Witham Academy	0	0	0	0	0	0	0	0
5	Priory City of Lincoln Academy	0	0	0	0	0	0	0	0
6	The Priory Academy LSST	3	0	0	3	3	8	-5	0





Year
9

Football

Year
10

Year 9/10 Girls' 5-a-side football fixtures



Tuesday 22nd November v. Priory LSST (H) League Lost 3-7
Goals: Imogen R x 3 P.O.M. Carly R

Tuesday 29th November v. LCHS (H) League Lost 0-4
Goals: P.O.M. Anna F

Thursday 5th January v. Branston (H) League Won 5-0
Goals: Imogen R x 4, Rosie N P.O.M. Imogen R

#	Team	P	W	D	L	F	A	GD	PTS
1	The Priory Academy LSST	3	3	0	0	18	6	12	9
2	Lincoln Christ's Hospital School	3	1	1	1	9	7	2	4
3	Sir Robert Pattinson Academy	3	1	0	2	8	11	-3	3
4	BRANSTON COMMUNITY ACADEMY 1	3	0	1	2	2	13	-11	1
5	Priory Pembroke Academy	0	0	0	0	0	0	0	0
6	The Queen Elizabeth's High School	0	0	0	0	0	0	0	0
7	William Farr C of E School	0	0	0	0	0	0	0	0
8	Priory City of Lincoln Academy	0	0	0	0	0	0	0	0





Check out the latest news; along with a new and updated calendar on our website.

www.srpa.co.uk

Social Media links:

[Twitter.com/@LincolnSRPA](https://twitter.com/@LincolnSRPA)

www.instagram.com/sirrobertpattinson



Instagram

Department Instagram accounts:

[Srpa_business-computing](#)

[Srpa_PE](#)

[Srpaperformingarts](#)

[Srpamaths](#)

[Srpaenglish](#)

[Srpaartandtechnology](#)

[Srpahumanities](#)

[Srpamfl](#)

[Sprascience](#)



Feedback

Compiling each term's newsletter is a big but exciting job. It is really important that we celebrate all the good that goes on at the Academy and would like feedback on our newsletter. If you have any ideas or suggestions, please do not hesitate to contact us; we welcome your thoughts!



Please use the QR Code above to leave any feedback

or email: enquiries@srpa.co.uk